

1.0 INTRODUCTION

This specification covers the application requirements of Measurement Specialties Accelerometer ACH-01. The ACH-01 is an inexpensive, general purpose accelerometer with outstanding performance characteristics. The use of piezoelectric polymer film in the ACH-01 provides many cost/performance advantages that allow it to be used in a wide range of applications where the use of traditional accelerometer technology is impractical. It is specifically designed for high volume applications which require the permanent installation of an accelerometer, such as machine health monitoring, modal analysis, automotive sensors, appliances, and feedback control systems.

Features of the accelerometer include:

- Wide Frequency Response
- Excellent Phase Response
- Wide Dynamic Range
- Low Cost
- Ultra-Low Power
- Very High Resonant Frequency
- Low Transverse Sensitivity
- Wide Temperature Range
- Small Temperature Dependence
- 3V to 40V Supply
- Impedance Buffered Output
- Excellent Linearity

Note: All dimensions in inches and are reference.

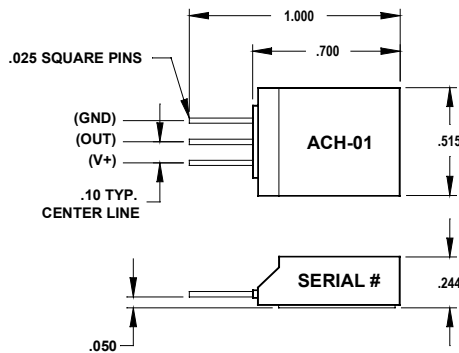

ACH-01-02 with Pins

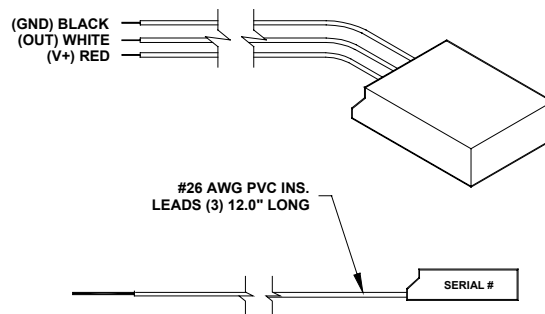

ACH-01-04 with Wires

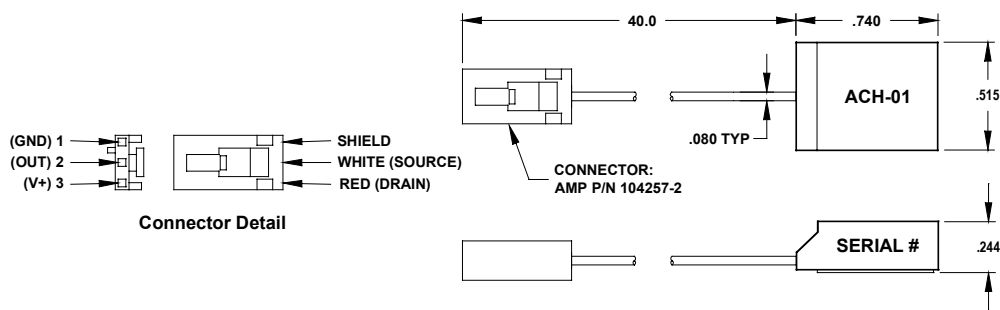

ACH-01-03 with Shielded Cable

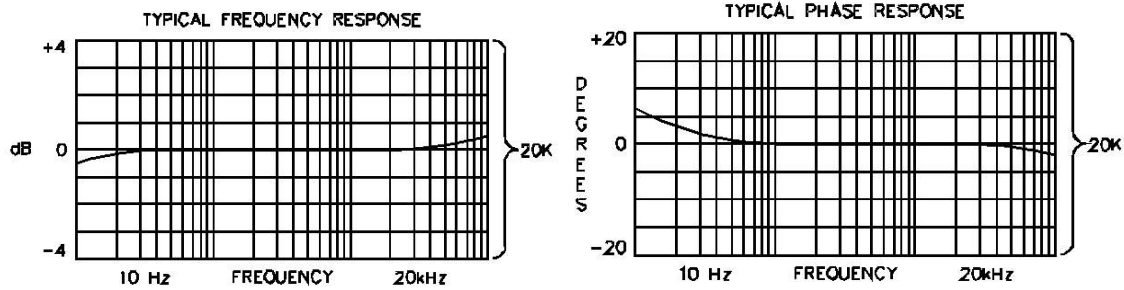

2.0 REFERENCE MATERIALS

2.1 Revision Summary

This paragraph is reserved for a revision summary of changes and additions made to this specification. Current revision reflects changes in the following areas: correction to polarity arrow in the figure on the upper part of page 4, correction of pin number layout on page 4, additions to specifications in section 2.6

2.2 Customer Assistance

Reference attached MSI Part Numbers and call (610) 650-1500 in the USA or +49 6074 862 822 in Europe to obtain additional product information.

2.3 Drawings

MSI Customer Drawings are available for specific products. The information contained in Customer Drawings takes priority if there is a conflict with this specification or with any other technical document supplied by MSI.

2.4 Applications Material

There is an interface amplifier available to simplify connection to the ACH-01, the IB-ACH-01. See MSI Instruction Sheet 408-9953.

2.5 Part Numbers

INTERFACE	DESIGNATOR	PART NUMBER
Pins	ACH-01-02	0-1000985-0
Shielded Cable	ACH-01-03	1-1001220-0
Discrete Wires	ACH-01-04	1-1001497-0
Amplifier Box	IB-ACH-01	0-1003058-0

If higher temperature or other non-standard specifications are required, please consult factory for alternative configurations and enhanced performance options.

2.6 Specifications

Performance (T=25°C)	Symbol	Min	Typ	Max	Units
Sensitivity	M _o	7	9	11	mV/g
Lower Frequency Limit (1)	f _l	--	2	5	Hz
Upper Frequency Limit (1)	f _u	10	20	--	kHz
Equivalent Noise Floor 10Hz 100Hz 1kHz		-- -- --	130 20 6	-- -- --	μg/√Hz
Dynamic Range	--	±150	--	--	g
Linearity	--	--	0.1	1.0	%
Transverse Sensitivity	M _t	--	2.0	5	%
Resonant Frequency	f _o	--	35	--	kHz
Phase Deviation (±5° Limit) (6)	θ	10	--	10,000	Hz
Supply Voltage	V+	3	--	40	Volts
Quiescent Supply Current	I _Q		10		μA
JFET Pinch Off Voltage	V _{gss}	-0.6	-0.8	-1.8	V
JFET Saturation Current	I _{dss}	30		90	μA
Output Impedance (6)	--	--	20	--	kΩ

Environmental Characteristics

Operating Temperature (2)	T _o	-40	--	85	°C
Storage Temperature	T _s	-40	--	85	°C
Maximum Shock Level	A _m	1000	--	--	g
Base Strain Sensitivity (3)	--	--	0.3	--	g/με
Transient Temp Sensitivity (4)	--	--	0.35	--	g/°C

Physical Characteristics

Weight (5) Cable	W	--	8	--	grams
------------------	---	----	---	----	-------

(1) ±3 dB limit

(3) @ 250με in base plane

(5) Includes 40" cable and connector

(2) ±2 dB from nominal M_o at 1kHz

(4) @ 3Hz LLF

(6) Typical Value

3.0 REQUIREMENTS

3.1 Mounting

Mounting methods play a critical role in determining the overall performance of any accelerometer. The ACH-01 is no exception. An improperly mounted accelerometer can give erroneous results. For this reason, MSI Sensors recommends the following mounting method to insure the proper performance of the ACH-01:

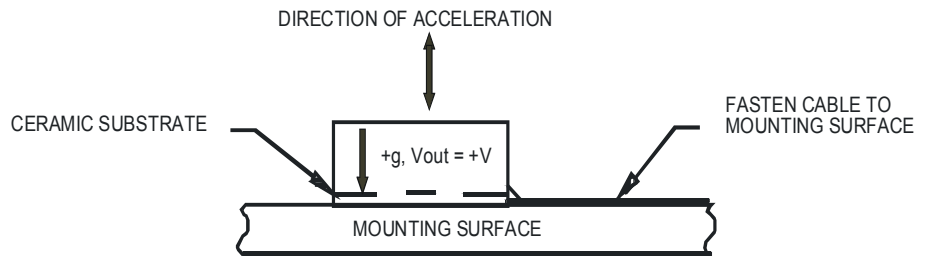

Adhesive Mounting Method - The surface should be flat. The area where the ACH-01 is to be mounted should be thoroughly cleaned to remove any dirt or oil present on the surface. Use a quick setting, viscous methyl cyanoacrylate adhesive such as Loctite's Black MaxJ or any epoxy such as Devcon's 5-Minute epoxy. Apply the adhesive sparingly to one surface following the manufacturer's directions. Apply pressure and allow the adhesive to set. Soft adhesives, such as double-sided tape or pressure sensitive adhesives, should not be used since they can adversely affect the ACH-01's performance. Cable should be adhered to the surface.

There is an interface amplifier available to simplify connection to the ACH-01, the IB-ACH-01. See Instruction Sheet 408-9953. In an effort to keep the product cost low the ACH-01 uses a ceramic substrate as the mounting base. Because of this the ACH-01 is susceptible to base strain and temperature transient effects. A mechanically rigid and thermally non-conductive mounting surface is highly recommended to limit these effects. MSI application engineers are available to recommend various mounting arrangements for your specific application.

3.2 Electrical Interface Circuits

The accelerometer ACH-01 accommodates various electrical interface circuits. A typical example is provided in the following figure. Since the ACH-01 uses the same internal JFET as Measurement Specialties= ACH-04-08-05 Multiple-Axis Accelerometer (Part Number: 1003800-5), additional circuit ideas can be found by reviewing Application Specifications 114-27002 and 144-70025. The ACH-01 equivalent electrical schematic is also shown.

GAIN STAGE

